

VERSATILE™ ADA PLUS

VS-1001-ADA



VS-1001-ADA-PC



ADA Shower Systems

GENERAL SPECIFICATION

Versatile ADA+ Shower components include hand held shower with 50 sprays and control with a non-positive shut-off feature. Pressure compensating flow control limits flow to 2.5 gpm/9.46 lpm maximum, to meet ASME A112.18.1 CSA B125.1 standard. 59" metal hose and swivel arm holder. 1/2" NPTF inlet in line vacuum breaker. 24" combination slide bar and grab bar, stainless steel and chrome. Meets the ANSI standard 250 lbs. pull-test for grab bars and with ADA lever handle for adjusting slide bar. Non-positive shut-off meets ICC/ANSI A117.1 SEC. 608.6 and ADAAG.

□ VS-1001-ADA

White finish ADA shower system.

□ VS-1001-ADA-PC

Polished chrome finish ADA shower system.

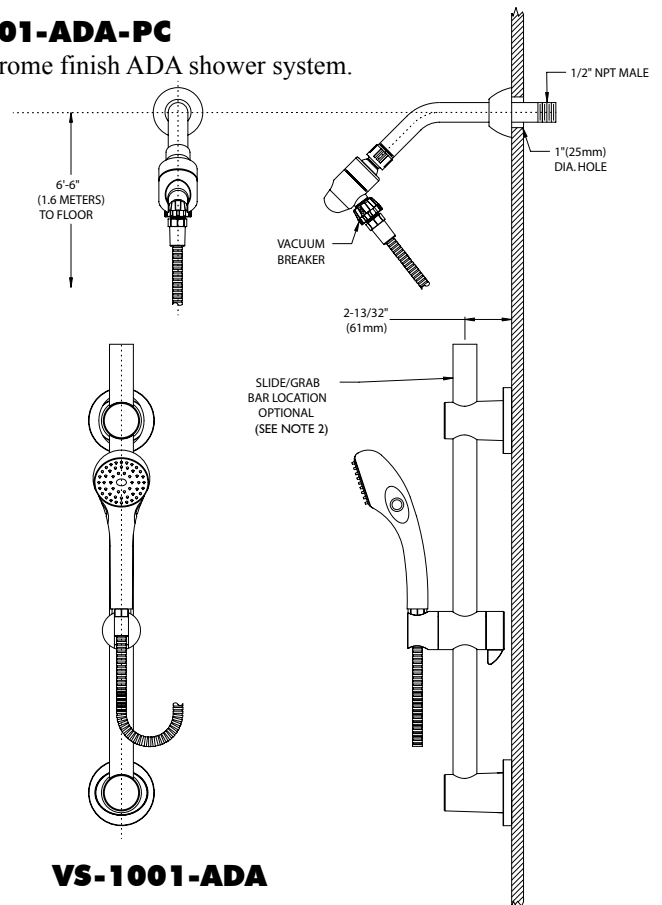

NOTE:
 1. ALL DIMENSIONS ARE IN INCHES (MILLIMETERS) UNLESS OTHERWISE SPECIFIED AND ARE SUBJECT TO CHANGE WITHOUT NOTICE.
 2. THE LOCATION OF THE SLIDE/GRAB BAR IS OPTIONAL, BUT RESTRICTED BY THE 69" HOSE LENGTH RUNNING FROM THE SHOWER ARM MOUNT BRACKET CONNECTION TO THE HAND SHOWER.
 3. FOR ADA MOUNTING LOCATIONS CONSULT ADAAG, ANSI A117.1, OR STATE REGULATIONS.

This space for Architect/Engineer approval.

