

FLUSH VALVES

Battery Powered Water Closet Flushometer

SWCV-2000



GENERAL SPECIFICATION

Solid brass polished chrome plated valve and cover. Adaptable to right and left hand installations. Factory set to meet 1.6 GPF requirements. Secure threaded tailpiece adjustment. Adjustable sensor focal distance and beam direction. Renewable seating surface. Maintenance mechanical override. 6 volt lithium battery. Low battery warning light. ADA compliant. Certified to UPC, ASSE 1037-90 and CSA B125.3-05

SWCV-2000

Battery operated water closet flushometer, valve only

OPTIONS

SUFFIX	DESCRIPTION
<input type="checkbox"/> VR	Vandal resistant override housing

This space for Architect/Engineer approval.



ROUGH-INS

SWCV-2000

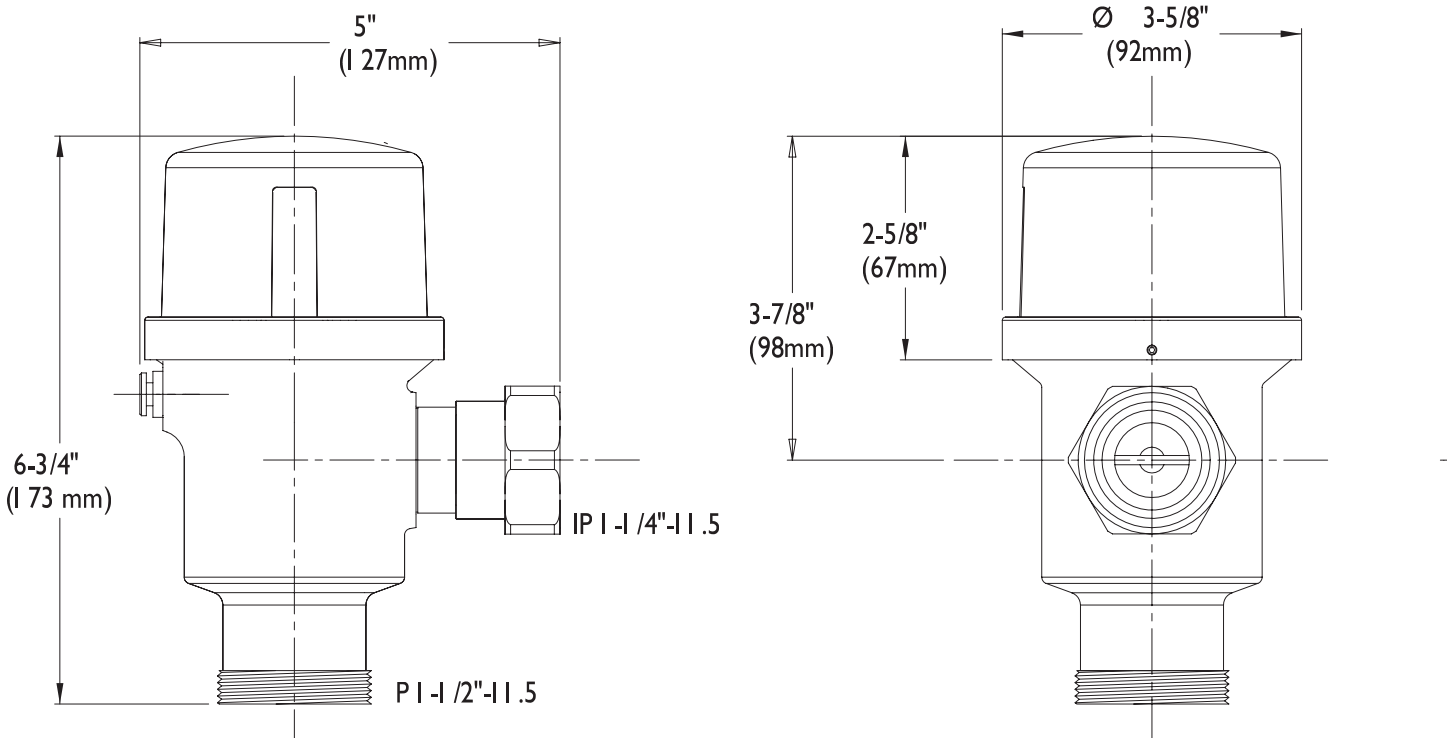

NOTE: All dimensions are in inches (millimeters) unless otherwise specified and are subject to change without notice. Unless otherwise specified, inlet is 1-1/4 NPSM female and outlet is 1-1/2 NPSM male.