

SPEAKMAN ALEXANDRIA™

Shower Combination SM-6090-ADA-P and SM-6080-ADA-P

SPECIFICATION

FEATURES:

- Traditional style
- SM-6000-P pressure balance shower valve & trim
- VS-3011 hand shower
- VS-155 elbow
- VS-156 pause/trickle adapter
- VS-153-ADA slide/grab bar
- SM-6090-P with S-1560 diverter tub spout with slip-fit connection
- SM-6080-P without S-1560 diverter tub spout

COMPLIANCE:

- Certified to ASME A112.18.1/CSA B125.1 and ASSE 1016 standards

AVAILABLE FINISHES:

ADD SUFFIX TO MODEL #

- Polished Chrome (standard)
- Brushed Nickel -BN

WARRANTY:

- 1 year limited

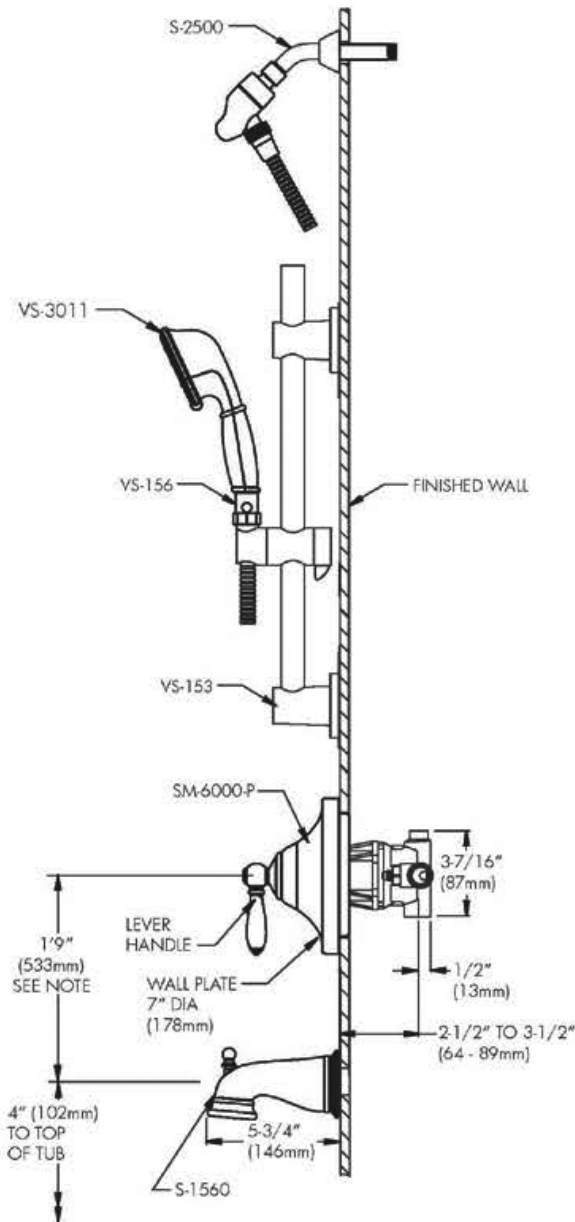

NOTE: 1. All dimensions are in inches (millimeters) unless otherwise specified and are subject to change without notice. 2. For ADA mounting locations, consult ADAAG, ANSI A117.1, or static regulations

THIS SPACE FOR ARCHITECT/ENGINEER APPROVAL.

SPEAKMAN®

400 ANCHOR MILL ROAD | NEW CASTLE, DE 19720
 P: 800-537-2107 | F: 800-977-2747
 WWW.SPEAKMANCOMPANY.COM



REVISION DATE: FEB. 2012