

SPEAKMAN ICON™

Pressure Balance Valve with Diverter & Trim SM-4400

SPECIFICATION

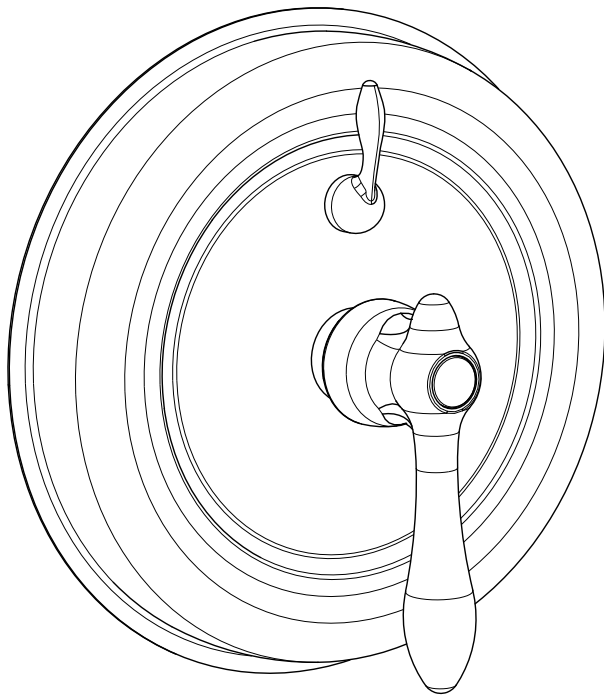

FEATURES:

- Diverter shower valve & trim kit
- Classic style
- Anti-scald pressure balance valve
- Built-in check valves
- Pressure balancing & ceramic temperature regulating cartridge
- Adjustable temperature limit stop
- Integral stops

COMPLIANCE:

- Certified to ASME A112.18.1/CSA B125.1 and ASSE 1016 standards

AVAILABLE FINISHES:

ADD SUFFIX TO MODEL #

- Polished Chrome (standard)

WARRANTY:

- 1 year limited

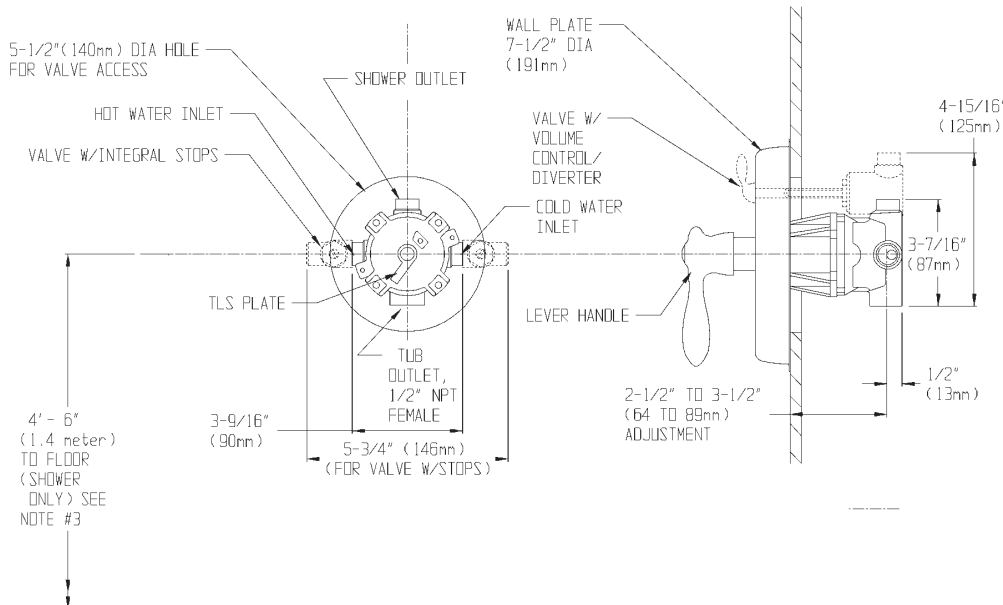

NOTE: 1. All dimensions are in inches (millimeters) unless otherwise specified and are subject to change without notice. 2. Unless otherwise specified, all inlets and outlets are 1/2" female copper sweat. 3. For ADA mounting locations, consult ADAAG, ANSI A117.1, or static regulations

THIS SPACE FOR ARCHITECT/ENGINEER APPROVAL.

SPEAKMAN®

400 ANCHOR MILL ROAD | NEW CASTLE, DE 19720
P: 800-537-2107 | F: 800-977-2747
WWW.SPEAKMANCOMPANY.COM



REVISION DATE: SEPT. 2011