

SPEAKMAN®

SE-925-TEW

COMBINATION EYEWASH & DRENCH HOSE

DESCRIPTION

The SE-925-TEW wall mounted combination drench hose/eyewash featuring stay open valve, twin aerated sprays with automatic flow control, 12' recoiling hose and flip-top dust covers.

SPECIFICATIONS

- Spray Heads:** Yellow plastic spray outlets with flip-top dust caps and an automatic flow control
- Valve:** 3/8" NPT female brass, chrome-plated
- Activator:** Brass, chrome-plated squeeze handle
- Hose:** 12' recoiling hose
- Inlet:** 3/8" NPT male, swivel connection
- Performance:** 2.37 gpm @ 30 psi
- Compliance:** ANSI Z358.1



OPTION

- VB Vacuum breaker

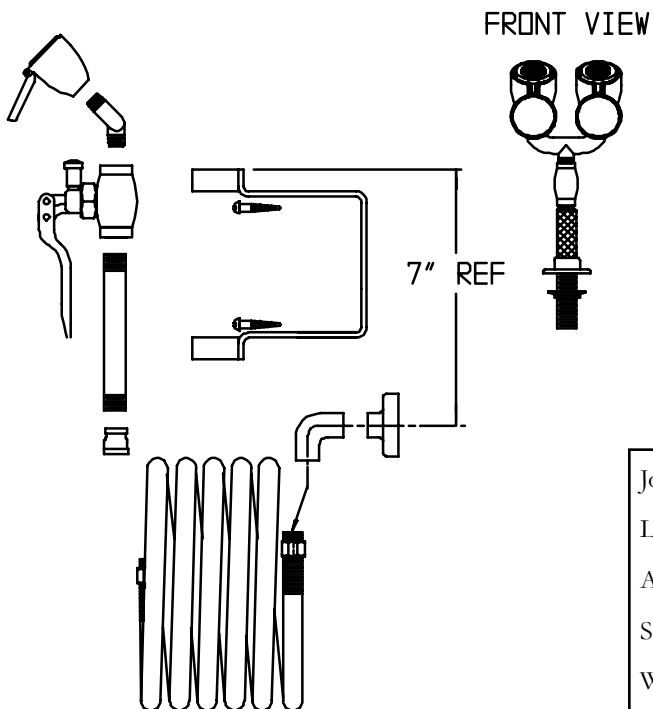

Job Name _____
Location _____
Architect/Engineer _____
Sales Representative _____
Wholesaler _____
Date _____ Model # _____