

SPEAKMAN®

SE-626

SAFE-T-ZONE® EMERGENCY SHOWER AND EYEWASH

DESCRIPTION

Combination station with SE-582 eyewash with dual spray outlets, flip top dust covers and stainless steel bowl, stainless steel stanchion with a deluge showerhead.

Activated by a stainless steel pull rod.

SPECIFICATIONS

Showerhead: 8" diameter stainless steel

Flow Control: Internal 20 gpm restrictor

Valve: 1" NPT female stainless steel.

Full flow stay-open ball valve

Activator: Stainless steel triangular pull rod

Stanchion: 1½" stainless steel, 18 gauge tubing

Inlet & Waste: 1¼" NPT male

Finish: Stainless steel

Performance: 20 gpm @ 20 psi

EYEWASH: SE-582

Bowl: 300 series stainless steel

Spray Heads: (2) aerated yellow plastic spray outlets with flip-top dust caps

Valve: ½" NPT stainless steel

Activator: Stainless steel push handle

Inlet: ½" NPT female

Performance: 3.6 gpm @ 30 psi

Compliance: ANSI Z358.1

Universal Emergency Sign Included

OPTIONS

- 30GPM 30gpm regulator
- XPR Extended pull rod
- HS Hand-held spray
- FLW Flow switch
- FPV Freeze protection valve
- SPV Scald protection valve
- HFO Hand & foot operation

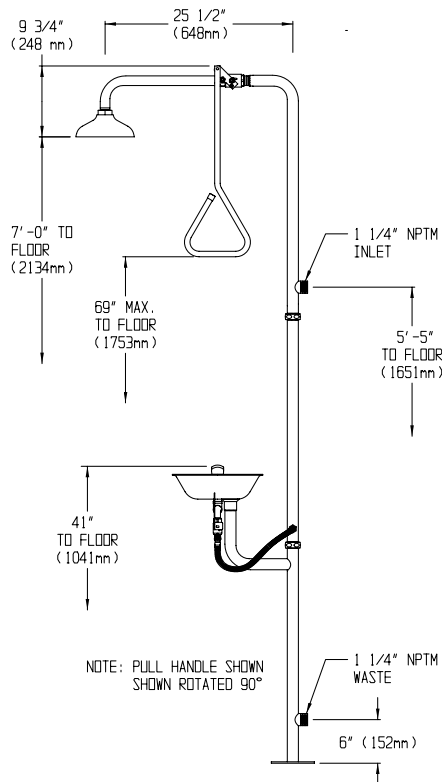

Job Name _____
Location _____
Architect/Engineer _____
Sales Representative _____
Wholesaler _____
Date _____ Model # _____