

# **SPEAKMAN®**

## **SE-594**

### HAND CART FOR TRANSPORT OF 5/10 GALLON TANK

#### DESCRIPTION

Wide handle hand cart for transporting the SE-590, SE-591, and SE-597 portable stainless steel eyewash tanks. Held in a platform/cradle assembly. The tank is secured using a strap and ratchet assembly.

#### SPECIFICATIONS

**CART:** Tubular Steel w/ 1/8" Thick Cradle Assembly

**SECURING MECHANISM:** 1" wide black Nylon webbing with metal ratchet for adjustment

**WHEELS:** 8" Dia. Molded Rubber

**FINISH:** DuraJade™

**Compliance:** ANSI Z358.1

**Universal Emergency Sign Included**

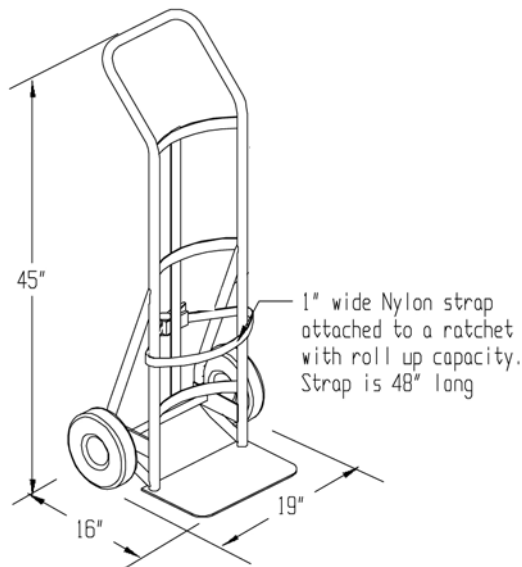

Job Name _____
Location _____
Architect/Engineer _____
Sales Representative _____
Wholesaler _____
Date _____ Model # _____