

# SPEAKMAN®

## SE-491

### EYESAVER® EYE/FACE WASH

**DESCRIPTION**

SE-491 Eyesaver® pedestal mounted eye/face wash features a stainless steel bowl, dual spray heads with automatic flow controls and flip top dust covers.

**SPECIFICATIONS**

- Bowl:** 300 Series Stainless Steel.
- Spray Heads:** (2) Yellow Plastic Spray Outlet, Sprayface, and Dust Cover.
- Valve:** 1/2" NPT Female Brass, Chrome-Plated.
- Activator:** Stainless Steel Push Handle.
- Inlet:** 1/2" NPT Female.
- Pipe:** 1-1/4" IPS Galvanized Steel.
- Waste:** 1-1/4" NPT Female.
- Finish:** Safety Green Paint.
- Compliance:** ANSI Z358.1
- Universal Emergency Sign Included**

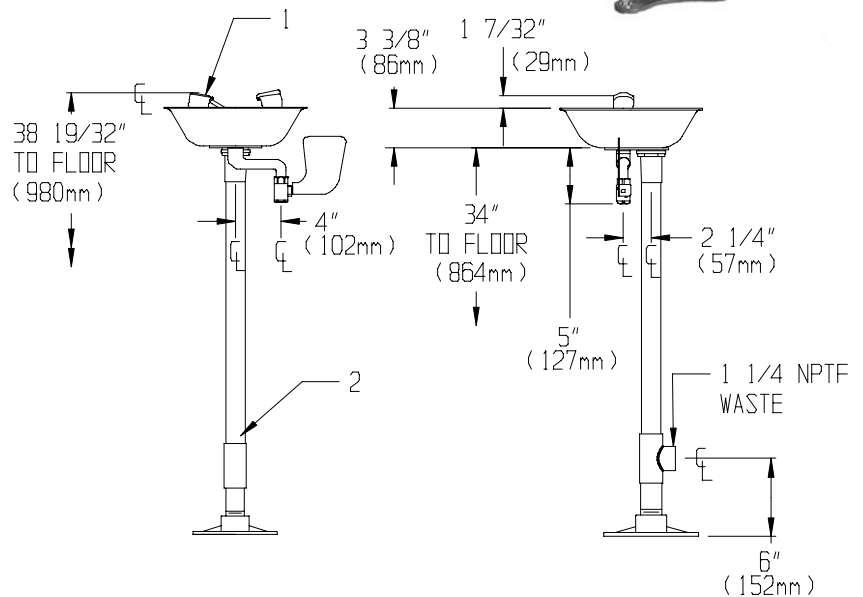

**OPTIONS**

- FLW Flow switch
- FPV Freeze protection valve
- HFO Hand/Foot operation
- HS Hand-held spray
- ILS In-line strainer
- SPV Scald protection valve
- SSBV Stainless steel ball valve

Job Name _____	
Location _____	
Architect/Engineer _____	
Sales Representative _____	
Wholesaler _____	
Date _____	Model # _____

36066