

SPEAKMAN®

SE-491-CV

EYESAVER® EYE/FACE WASH

DESCRIPTION

Pedestal mounted emergency covered eye/face wash. Supplied with stainless steel bowl, stainless steel cover, stay-open full flow ball valve; activated by stainless steel push handle; twin spray heads with individual flow restrictors, and flip-off dust covers.

SPECIFICATIONS

- Bowl: 300 Series Stainless Steel.
- Cover: 300 Series Stainless Steel.
- Spray Heads: (2) Yellow Plastic Spray Outlet, Sprayface, and Dust Cover.
- Valve: ½" NPT Female Brass, Chrome-Plated
- Activator: Stainless Steel Push Handle
- Inlet: ½" NPT Female
- Pipe: 1¼" IPS Galvanized Steel
- Floor Flange: Brass Casting with (3) 17/32" diameter mounting holes on 9" diameter bolt circle spaced 120° apart
- Waste: 1¼" NPT Female.
- Finish: DuraJade™
- Performance: 4.5 gpm @ 30 psi
- Compliance: ANSI Z358.1
- Universal Emergency Sign Included

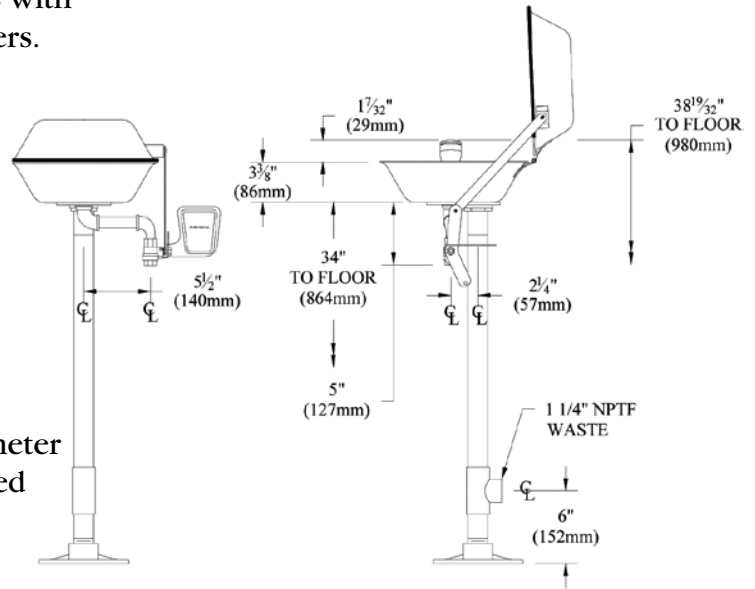

OPTION

- HFO Hand foot operation
- FLW Flow switch
- HS Hand-held spray
- FPV Anti-freeze protection valve
- SPV Anti-scald Protection valve
- SSBV2 1/2" stainless steel valve

Job Name _____
Location _____
Architect/Engineer _____
Sales Representative _____
Wholesaler _____
Date _____ Model # _____