

SPEAKMAN®

SE-490-SS

EYESAVER® EYE/FACE WASH

DESCRIPTION

Wall-mounted, push-handle activated emergency eye/face wash with all stainless steel construction. Supplied with stainless steel bowl and stay-open full flow ball valve. Features heavy-duty wall mounting plate and twin spray heads with balance control screw and flip-top dust caps.



SPECIFICATIONS

- Bowl:** 300 series stainless steel
- Spray Heads:** (2) 304 stainless steel
- Valve:** 1/2" NPT female brass 304 stainless steel
- Activator:** 304 stainless steel push handle
- Inlet:** 1/2" NPT female
- Performance:** 3.82 gpm @ 30 psi
- Compliance:** ANSI Z358.1
- Universal Emergency Sign Included**

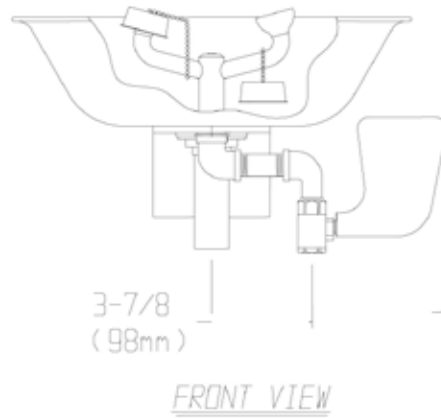
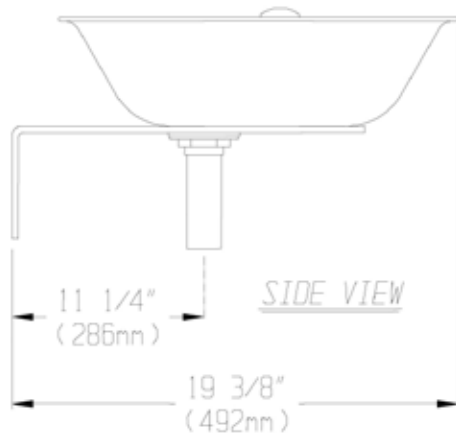

OPTIONS

- FLW Flow switch
- FPV Freeze protection valve
- HFO Hand/Foot operation
- HS Hand-held spray
- PT P-trap
- SPV Scald protection valve

Job Name _____
Location _____
Architect/Engineer _____
Sales Representative _____
Wholesaler _____
Date _____ Model # _____