

SPEAKMAN®

SE-235

LIFESAVER® EMERGENCY SHOWER

DESCRIPTION

The SE-235 Lifesaver® Emergency Shower features concealed ceiling mounting, supplied with self-closing valve activated by pull chain, flange for attachment to wall or floor, and ceiling ferrule.

SPECIFICATIONS

Showerhead: 10" dia. brass, chrome-plated with polished shower head flange

Flow Control: Internal 20 gpm restrictor

Valve: 1" NPT female brass, chrome-plated, self-closing valve.

Flange: Brass, chrome plated

Pipe: 1" IPS galvanized steel

Ferrule: Brass, chrome plated

Activator: Stainless steel loop chain, 120" long

Performance: 20 gpm @ 20 psi

Compliance: ANSI Z358.1

Universal Emergency Sign Included

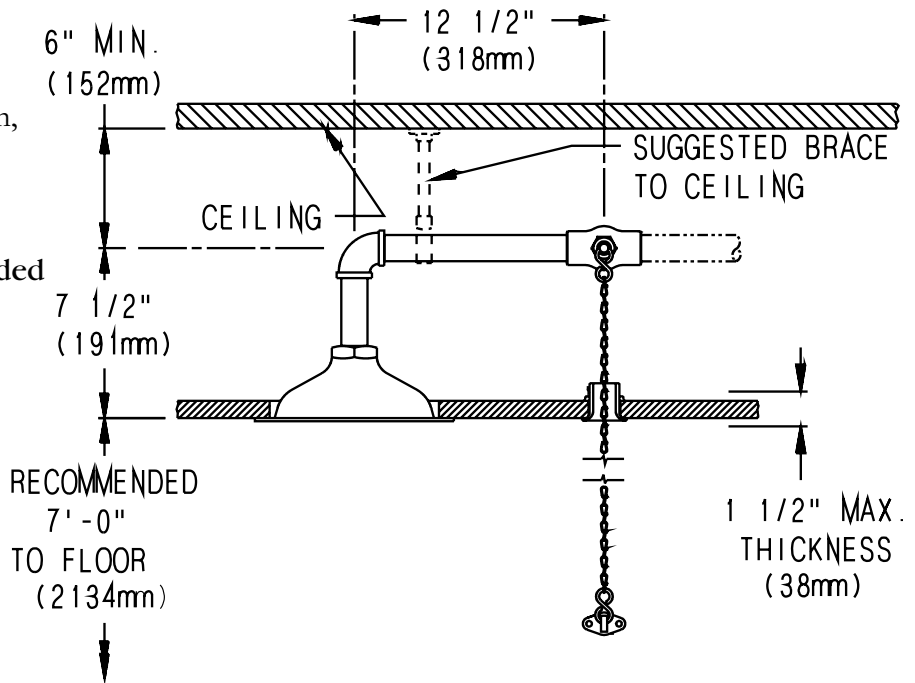

OPTIONS

- 30GPM 30gpm regulator
- FLW Flow switch
- PC Polished chrome showerhead
- FPV Anti-freeze protection valve
- SPV Anti-scald protection valve
- SSH Stainless steel showerhead
- SSH Stainless steel showerhead

Job Name _____	
Location _____	
Architect/Engineer _____	
Sales Representative _____	
Wholesaler _____	
Date _____	Model # _____

3444