

SPEAKMAN COMPANY

S-8801 Installation, Maintenance & Operation Instructions **SENSORFLO® AC/ELECTRIC POWERED LOW SPOUT LAVATORY FAUCET**

DESCRIPTION

Speakman SENSORFLO faucet. AC/Electric powered low spout lavatory sensor faucet including under counter mixing valve with built-in backflow check valves. All metal spout assembly, consists of polished chrome plated removable cover and black powder coated chassis. Sensor/electronics module housed above counter in the faucet body. Sensor module powered by 120 Volt AC transformer. Solenoid with built-in filter. Vandal resistant 60 second time out feature. Water conserving vandal resistant recessed aerator reduces water flow to 2.2 GPM / 8.4 LPM to meet requirements of ANSI A112.18.1M for flow rates. ADA compliant. Note: 3/8" compression stainless steel hoses are optional.

SPECIFICATIONS

TRANSFORMER: 120 VOLT AC
INLET SUPPLY: 3/8" COMPRESSION WITH MALE THREADS
FLOW RATE: 2.2 GPM / 8.4 LPM
SHIPPING WEIGHT: 5.1 LBS

OPTIONS

BO – Vandal Resistant 0.5 GPM Flow Control	LF – Vandal Resistant Laminar 2.2 GPM Flow Control
HS – 2 Stainless Steel Hoses for use with Under Counter Mixer	LT - Less Transformer (for use w/ multi-unit transformers)
GB- Vandal Resistant 1.5 GPM Aerator Outlet Device	VRS - Vandal Resistant Screws with Wrench

INSTALLATION

Install vandal resistant aerator with wrench provided. Ensure gasket is properly seated on bottom of faucet chassis. Carefully feed wires from faucet through deck hole, mounting faucet on fixture. Attach notched wire guard (notched end up) washer and lock nut onto faucet shank and secure faucet to fixture. CAUTION: Sensor module wire must be inside channel of rubber wire guard to keep wire from being pinched or cut when tightening washer and lock nut. Attach outlet of solenoid valve to shank of faucet. Attach under counter mixing valve to inlet of solenoid, attach supplies to mixing valve using 3/8" compression fittings. DRY CONNECTIONS ONLY. Plug AC transformer unit into 120 VAC outlet and connect wire with black plug on faucet to plug on the transformer. Connect yellow wire from faucet to same colored wire on solenoid valve. With drain installed, turn on water and activate the faucet, checking for proper operation and all connections for leaks. Once positive faucet is operating properly adjust temperature of water delivered by rotating the adjusting screw (clockwise for more cold water) on the mixer until the proper mix of hot and cold water is achieved.

OPERATION

Speakman SENSORFLO faucets are thoughtfully designed for all in mind. Require no handles to turn, lift or push, water flows only when hands are in the lavatory basin. Built in vandal resistant circuitry shuts off the water after continuous flow of approximately 60 seconds. This feature prevents flooding; water is easily turned on again by placing one's hands under the lavatory spout.

MAINTENANCE (CARE & CLEANING)

Your SENSORFLO faucet is designed and engineered in accordance with the highest quality and performance standards. With proper care it will provide years of trouble free service. Periodically the faucet will require some minor maintenance to keep it performing at peak performance. Periodically check the solenoid filter for debris. If debris is present clean the filter toughly. The polished chrome finish of your faucet should be cleaned using mild soap and warm water. Dry immediately with a soft, clean cloth for best results.

S-8801 SERIES

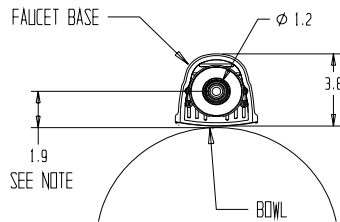
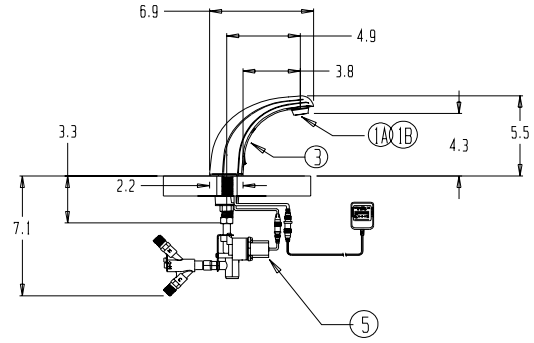
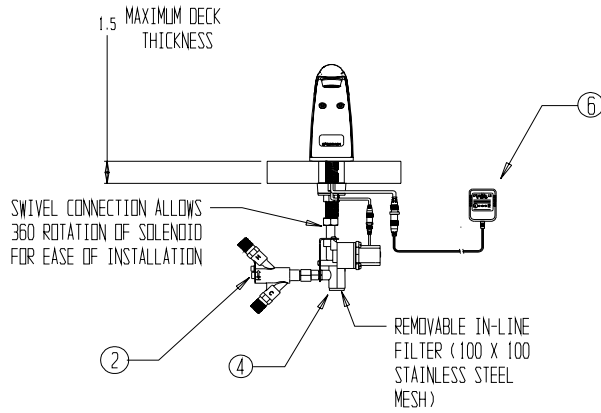

NOTE: *

POSITION FAUCET AS CLOSE TO THE EDGE OF THE SINK AS POSSIBLE. ENSURE ADEQUATE CLEARANCE FOR WIRE PROTECTOR, WIRES, WASHERS, AND NUT.

NOTES:

1. INLET IS 3/8" COMPRESSION WITH MALE THREADS.
2. ALL DIMENSIONS ARE IN INCHES (MILLIMETERS) UNLESS OTHERWISE SPECIFIED AND ARE SUBJECT TO CHANGE WITHOUT NOTICE.

REPAIR / REPLACEMENT PARTS

ITEM NUMBER	PART OR GROUP NUMBER	DESCRIPTION
1A	RPG05-0674-PC	2.2 GPM AERATOR
1B	RPG38-0128-PC	0.5 GPM FLOW CONTROL
2	RPG20-1845	UNDER COUNTER MIXER
3	RPG10-0068-PC	COVER WITH SCREWS
4	RPG66-0044	SOLENOID FILTER SCREEN
5	RPG76-0033	SOLENOID VALVE ASSEMBLY
6	RPG66-0010	120 VAC TRANSFORMER
NOT SHOWN	RPG76-0039	SOLENOID DIAPHRAM & O-RING REPAIR KIT
NOT SHOWN	RPG66-0159	LAVATORY SENSOR MODULE WITH AC ADAPTER

SPEAKMAN®

PO Box 191 Wilmington, DE 19899

Phone: 800-537-2107 Fax: 800-977-2747

Visit us on the web at www.speakmancompany.com