

SPEAKMAN CASPIAN™

Showerhead S-3014

SPECIFICATION



FEATURES:

- 50 adjustable spays
- Massage spray setting
- Contemporary design
- 360° spray adjusting faceplate

AVAILABLE FINISHES:

ADD SUFFIX TO MODEL #

- Polished Chrome (standard)
- Brushed Nickel -BN
- Polished Nickel -PN

COMPLIANCE:

- Certified to ASME A112.18.1/CSA B125.1 standards
- WaterSense certified (E2)



OPTIONS:

- 2.0 gpm (9.5 L/min) flow rate -E2

WARRANTY:

- 1 year limited

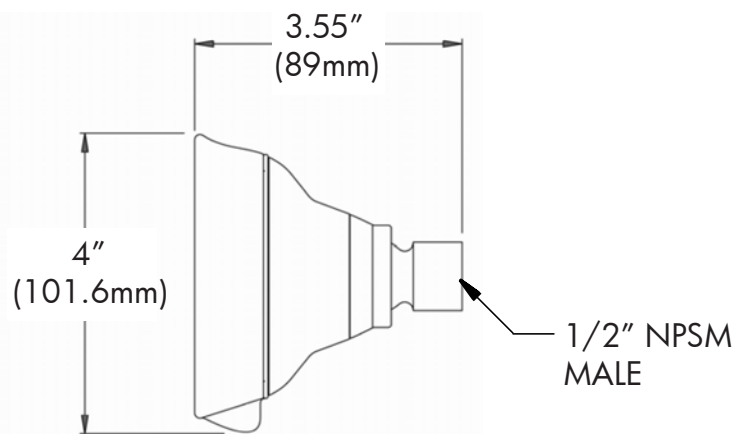
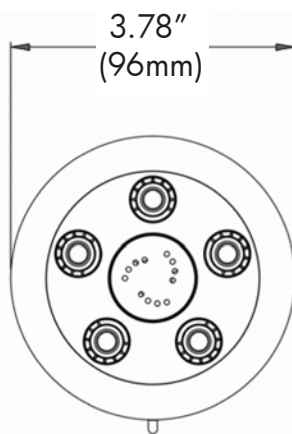

NOTE: 1. All dimensions are in inches (millimeters) unless otherwise specified and are subject to change without notice.

THIS SPACE FOR ARCHITECT/ENGINEER APPROVAL.

SPEAKMAN®

400 ANCHOR MILL ROAD | NEW CASTLE, DE 19720
P: 800-537-2107 | F: 800-977-2747
WWW.SPEAKMANCOMPANY.COM



REVISION DATE: SEPT. 2011