

SPEAKMAN RAINIER™

Arm & Flange S-2550

SPECIFICATION

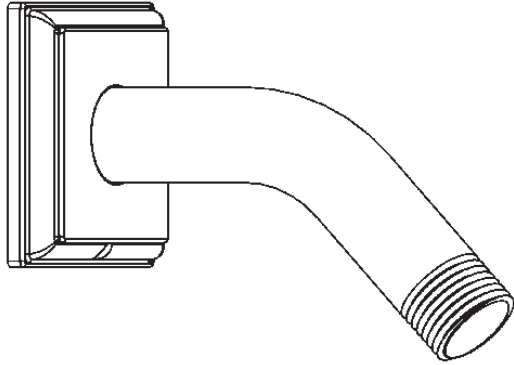

FEATURES:

- Brass construction
- 7" length
- 1/2" NPTM inlet & outlet

AVAILABLE FINISHES:

ADD SUFFIX TO MODEL #

- Polished Chrome (standard)

WARRANTY:

- 1 year limited

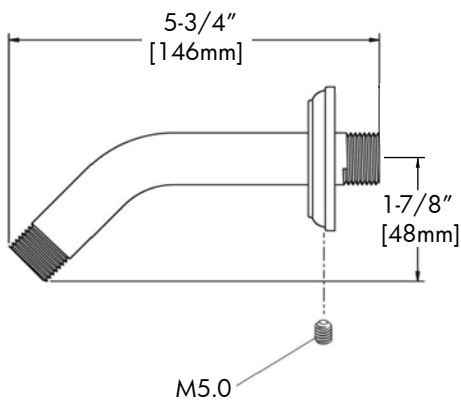
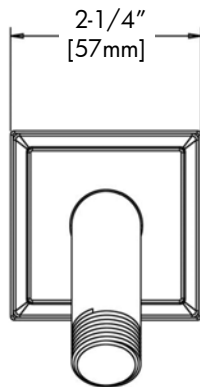

NOTE: 1. All dimensions are in inches (millimeters) unless otherwise specified and are subject to change without notice.

THIS SPACE FOR ARCHITECT/ENGINEER APPROVAL.

SPEAKMAN®

400 ANCHOR MILL ROAD | NEW CASTLE, DE 19720
P: 800-537-2107 | F: 800-977-2747
WWW.SPEAKMANCOMPANY.COM



REVISION DATE: SEPT. 2011