

SPEAKMAN COMPANY

S-2252 Installation, Maintenance & Operation Instructions

ANYSTREAM® SHOWERHEAD

DESCRIPTION

Polished chrome plated ANYSTREAM showerhead. Brass ball swivel joint. Brass shank. Contoured polished chrome plated brass spray adjusting handle. Polished chrome plated 2-3/4" face. 6 Lexan deposit resisting plungers with 48 spray channels. Water conserving pressure compensating AUTOFLO® device reduces flow to 2.5 GPM/9.46LPM maximum, to meet existing ANSI A112.18.1 Standard. 1/2" NPT inlet.

SPECIFICATIONS

SUPPLY INLET: 1/2" NPTF
 FLOW RATE: 2.5 GPM/9.46LPM
 MAX.
 SHIPPING WEIGHT: 1.26 LBS.

OPTIONS

◇ ORB: Oil Rubbed Bronze	◇ PB: Polished Brass PVD Coating
◇ BPT: British Pipe Thread	◇ BN: Brushed Nickel
◇ PN: Polish Nickel	◇ S-2252-E2: Low Flow Showerhead (2.0 GPM/ 7.6 LPM)

INSTALLATION

Apply pipe thread tape in a clockwise direction to threads of shower arm. Pipe joint compound may be used instead of tape. Turning in a clockwise direction, thread the shower head on to the shower arm. Tighten with a pipe wrench or a pair of pliers. Position the shower head by rotating it clockwise. Make sure the ball joint coupling nut is properly tightened. Turn the water supply on and check for leaks. **NOTE: THE S-2252 SHOWERHEAD FACEPLATE HAS A CLEAR PROTECTIVE COVER WHICH CAN BE REMOVED BY RUNNING THE FACEPLATE UNDER WARM WATER AND THEN REMOVING THE COVER WITH ANY ONE-SIDED TAPE.**

OPERATION

To adjust the spray pattern of the shower head, simply rotate the handle to the desired spray (needle spray, gentle rain or full flood).

Product improvements may cause specification and dimensional changes without notice.

MAINTENANCE

Your Speakman showerhead is designed and engineered in accordance with the highest quality and performance standards. Periodic cleaning using a mild soap and warm water will help keep your showerhead's appearance in its original condition. For best results, dry immediately with a soft, clean cloth. **Do Not Use** harsh and/or abrasive cleaners on showerheads. To help restore your finish, occasionally apply a non-abrasive wax to your showerhead body (Follow manufacturer's instructions). In certain water conditions, mineral deposits may form on your faceplate. To reduce the mineral build-up, turn the handle to **FLOOD** position to let the water drain out after every use. A gentle scrubbing of the plunger or channels with a toothbrush should restore your spray pattern. On **chrome** plated showerheads, a white vinegar/water treatment will assist in breaking down excessive mineral deposits on the sprays. The showerhead faceplate can be soaked in a two (2) parts white vinegar and (1) part water solution for about 1/2 hour to break up the mineral deposits. Rinse thoroughly. Brush off any remaining mineral deposits if necessary. **CAUTION:** On all special finish parts, including any of the nickel or brass finishes, the white vinegar/water treatment should not be used.

ROUGH-IN MEASUREMENTS

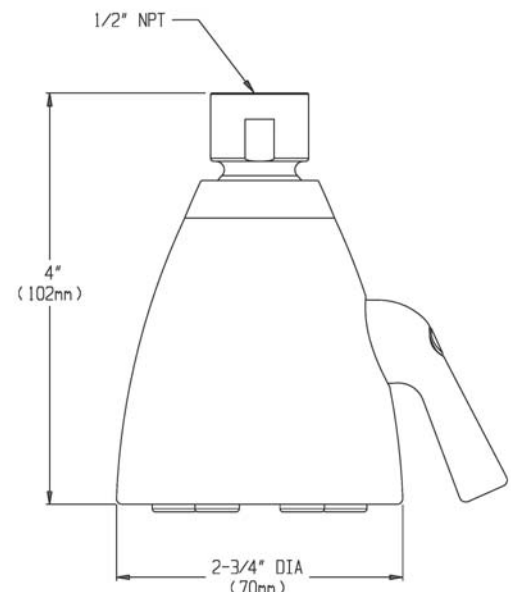

SPEAKMAN®

PO Box 191 Wilmington, DE 19899 Phone: 800-537-2107 Fax: 800-977-2747
 Visit us on the web at www.speakmancompany.com

03/11
 REV 2
 92-3206